

## Description



Metal Oxide Varistor (MOV) is a nonlinear resistance component with zinc oxide (ZnO) as its main constituent. The resistance of an MOV is sensitive to changes in the applied voltage. Below the threshold voltage, the MOV exhibits high resistance, allowing only a negligibly small leakage current to flow. Once the threshold voltage is exceeded, the resistance of the MOV drops sharply, enabling the conduction of a large current. This characteristic makes the MOV suitable for detecting and suppressing surge voltage and overvoltage, thereby protecting the circuit from damage caused by excessive voltage.

The Metal Oxide Varistor (MOV) finds wide application in various fields such as photovoltaics, communication, lightning protection, power supply, and power strips. It serves to suppress transient overvoltage and absorb surge energy within the circuit.

SETsafe | SETfuse offers Metal Oxide Varistors (MOV) with maximum peak current ratings ranging from 8 kA to 50 kA, and maximum continuous voltage ratings from 130VAC to 750 VAC. Safety certification includes UL, cUL, TUV, and CQC, and complies with RoHS and REACH requirements.

## Product Structure

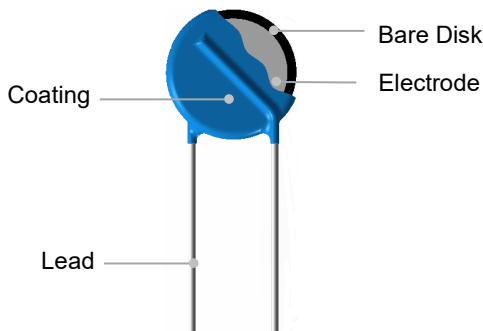

## Lead Types

Lead Types	Codes
Straight Lead	A
Outward Crimp Lead	C
Inline Crimp Lead	I
Little Straight Lead	D

## Agency Information

Agency	Standards	No.
	UL 1449 5 <sup>th</sup> Edition	E322662
	CSA C22.2 NO.269.5-17	E322662
	EN IEC 61051-1:2018 EN IEC 61051-2:2021 IEC 61051-2-2:1991 Annex G.8.1 of IEC 62368-1:2018	J 50239739
	GB/T 10193-1997 GB/T 10194-1997 GB 4943.1-2022 IEC 61051-2-1991+Amd1:2009	CQC12001084355

## Applications

- Power Supplies
- Home Electrical Appliances
- Industrial Devices
- Surge Protectors
- Telecom Devices

### Marking

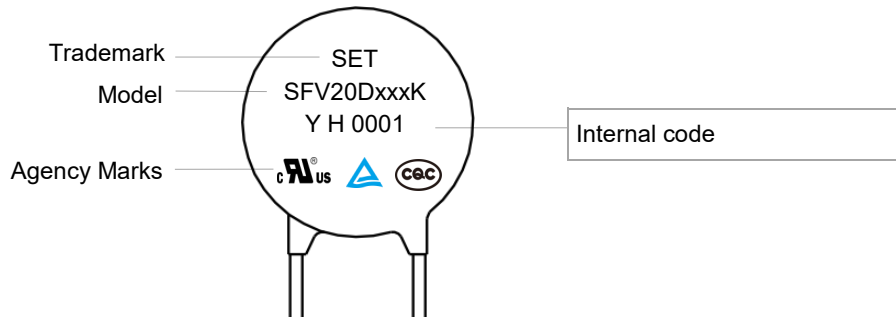

### Temp. Derating Curve

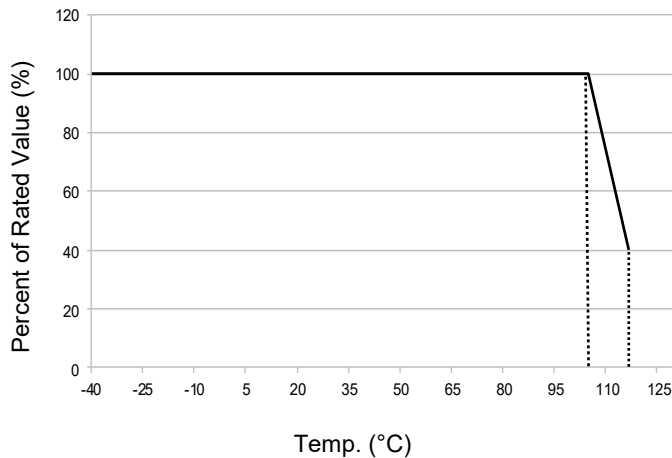

**Note:**

When ambient Temp. exceeds 105 °C, the peak surge current and energy rating should be reduced as shown in left curve.

For Normal Temp. Series

### General Technical Data

Item	Value	Unit
Operating Temperature	-40 to +105	°C
Storage Temperature	-40 to +125	°C
Voltage Proof	≥2500	V <sub>ac</sub>
Insulation Resistance	≥100	MΩ

**Dimensions (mm)**

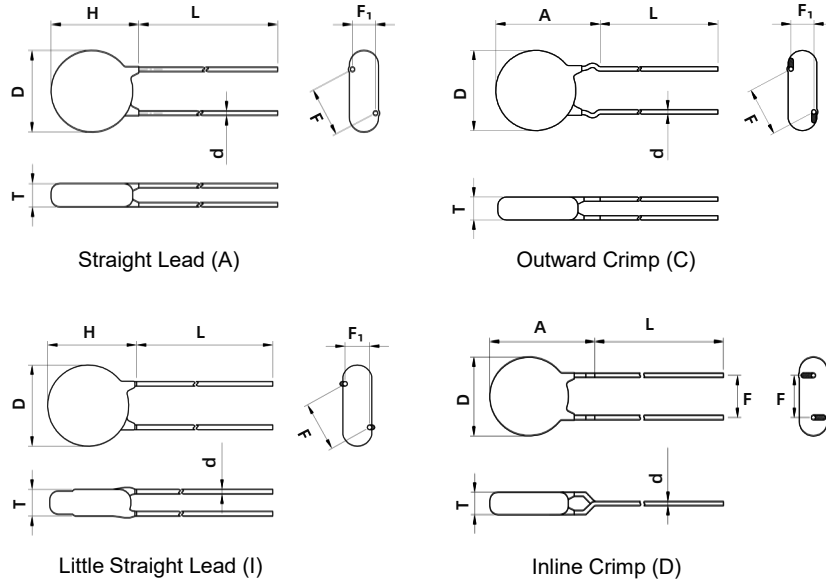
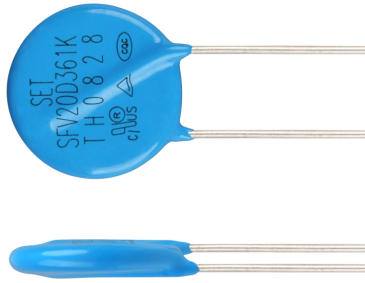

Model	L (Min.)	H (Max.)	T (Max.)	D (Max.)	d	F	F <sub>1</sub>	A (Max.)
SFV20D201K	20	25.5	4.8	23	1.00±0.05	10.0±0.5	1.0 ~ 3.0	27.5
SFV20D221K	20	25.5	4.9	23	1.00±0.05	10.0±0.5	1.0 ~ 3.0	27.5
SFV20D241K	20	25.5	5.0	23	1.00±0.05	10.0±0.5	1.1 ~ 3.1	27.5
SFV20D271K	20	25.5	5.2	23	1.00±0.05	10.0±0.5	1.3 ~ 3.3	27.5
SFV20D301K	20	25.5	5.3	23	1.00±0.05	10.0±0.5	1.4 ~ 3.4	27.5
SFV20D331K	20	25.5	5.5	23	1.00±0.05	10.0±0.5	1.6 ~ 3.6	27.5
SFV20D361K	20	25.5	5.6	23	1.00±0.05	10.0±0.5	1.7 ~ 3.7	27.5
SFV20D391K	20	25.5	5.8	23	1.00±0.05	10.0±0.5	1.9 ~ 3.9	27.5
SFV20D431K	20	25.5	6.0	23	1.00±0.05	10.0±0.5	2.0 ~ 4.0	27.5
SFV20D471K	20	25.5	6.2	23	1.00±0.05	10.0±0.5	2.2 ~ 4.2	27.5
SFV20D511K	20	25.5	6.4	23	1.00±0.05	10.0±0.5	2.4 ~ 4.4	27.5
SFV20D561K	20	25.5	6.6	23	1.00±0.05	10.0±0.5	2.7 ~ 4.7	27.5
SFV20D621K	20	25.5	6.9	23	1.00±0.05	10.0±0.5	3.0 ~ 5.0	27.5
SFV20D681K	20	25.5	7.2	23	1.00±0.05	10.0±0.5	3.2 ~ 5.2	27.5

Note:  
The above data is for reference only.

### Part Numbering System



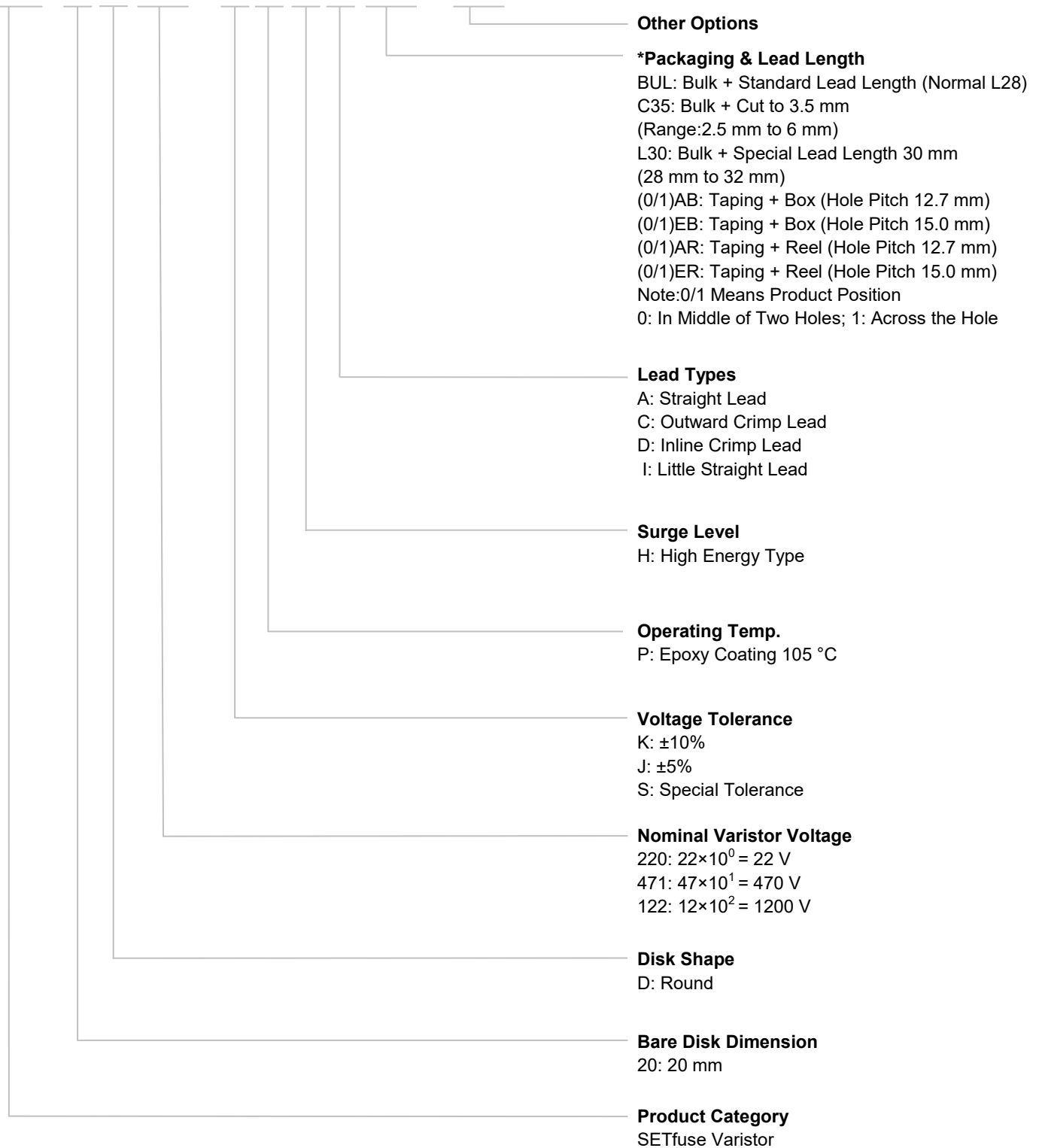

SFV 20 D 471 - K P H A BUL - 001



**Reminder:**

Part numbering system in the datasheet is only for selecting correct parameter and product features. Before placing order, please contact us for specifications and use the part number and product code in the specifications to place order to ensure the part is correct. Product code is the unique identification.

**Specification**

Model	Surge Level	Max. Continuous Operating Voltage		Varistor Voltage @1 mA DC		Clamping Voltage (Max.)		Max. Peak Current (1 time, 8/20 μs)	Max. Energy (8/20 μs)	Typical Capacitance (For reference only) @1 kHz	Agency Information						
		VAC	VDC	Min.	Max.	V <sub>C</sub>	I <sub>P</sub>				H		(pF)				
		(V)	(V)	(V)	(V)	(V)	(A)				(kA)	(J)		UL	cUL	TUV	CQC
SFV20D201K	H	130	170	180	220	340	100	13	300	2000	●	●	●	●			
SFV20D221K	H	140	180	198	242	360	100	13	320	1800	●	●	●	●			
SFV20D241K	H	150	200	216	264	395	100	13	340	1650	●	●	●	●			
SFV20D271K	H	175	225	243	297	455	100	13	380	1500	●	●	●	●			
SFV20D301K	H	190	250	270	330	500	100	13	400	1300	●	●	●	●			
SFV20D331K	H	210	275	297	363	550	100	13	440	1200	●	●	●	●			
SFV20D361K	H	230	300	324	396	595	100	13	470	1100	●	●	●	●			
SFV20D391K	H	250	320	351	429	650	100	13	510	1000	●	●	●	●			
SFV20D431K	H	275	350	387	473	710	100	13	550	930	●	●	●	●			
SFV20D471K	H	300	385	423	517	775	100	13	600	850	●	●	●	●			
SFV20D511K	H	320	415	459	561	845	100	13	650	780	●	●	●	●			
SFV20D561K	H	350	460	504	616	925	100	13	700	710	●	●	●	●			
SFV20D621K	H	385	505	558	682	1025	100	13	700	650	●	●	●	●			
SFV20D681K	H	420	560	612	748	1120	100	13	800	600	●	●	●	●			

●: Approved      ○: Unauthorized      ●: RoHS & REACH Compliant

### Packaging Information

- Bulk Packaging (Code: BUL)
- Bulk Packaging Quantity & Weight.

Series	Nominal Varistor Voltage	PE Bag	Box	Carton	G. W / Carton (365 × 265 × 245)
	(V)	(PCS)	(PCS)	(PCS)	(kg)±10%
SFV20D Series	201 ~ 471	250	500	3000	11 ~ 16
	511 ~ 681	200	400	2400	14 ~ 18

Note:

Other lead length packaging information, please contact SETsafe | SETfuse.

All Dimensions in mm

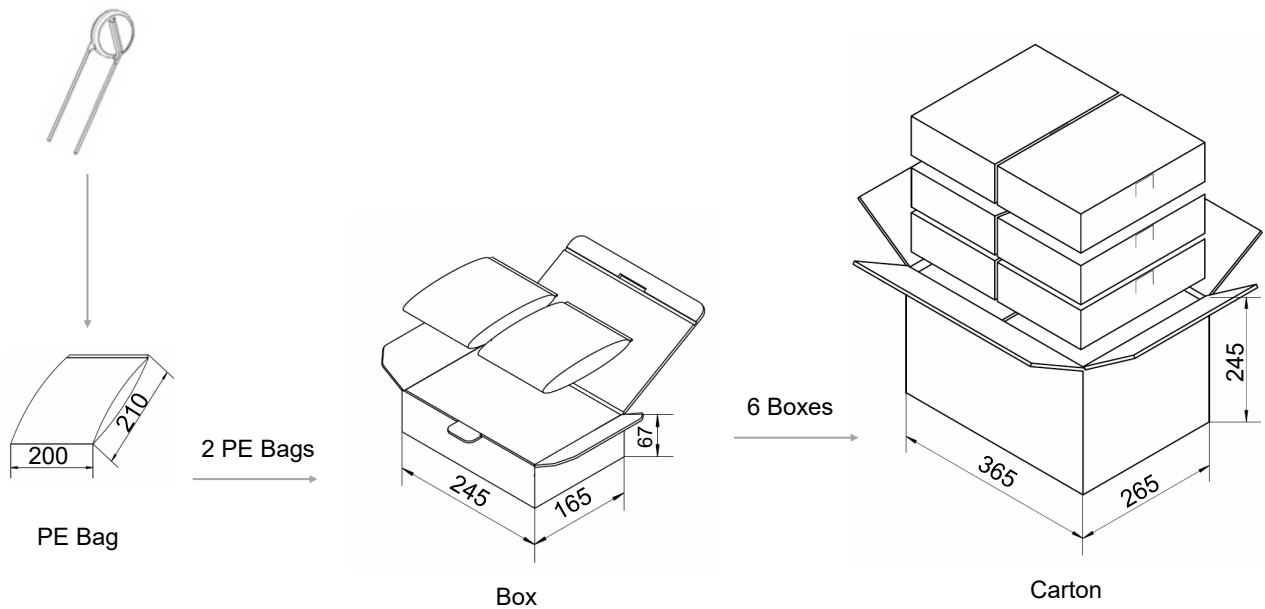

**Packaging Information**

- Tape Packaging (Code: 1AB)

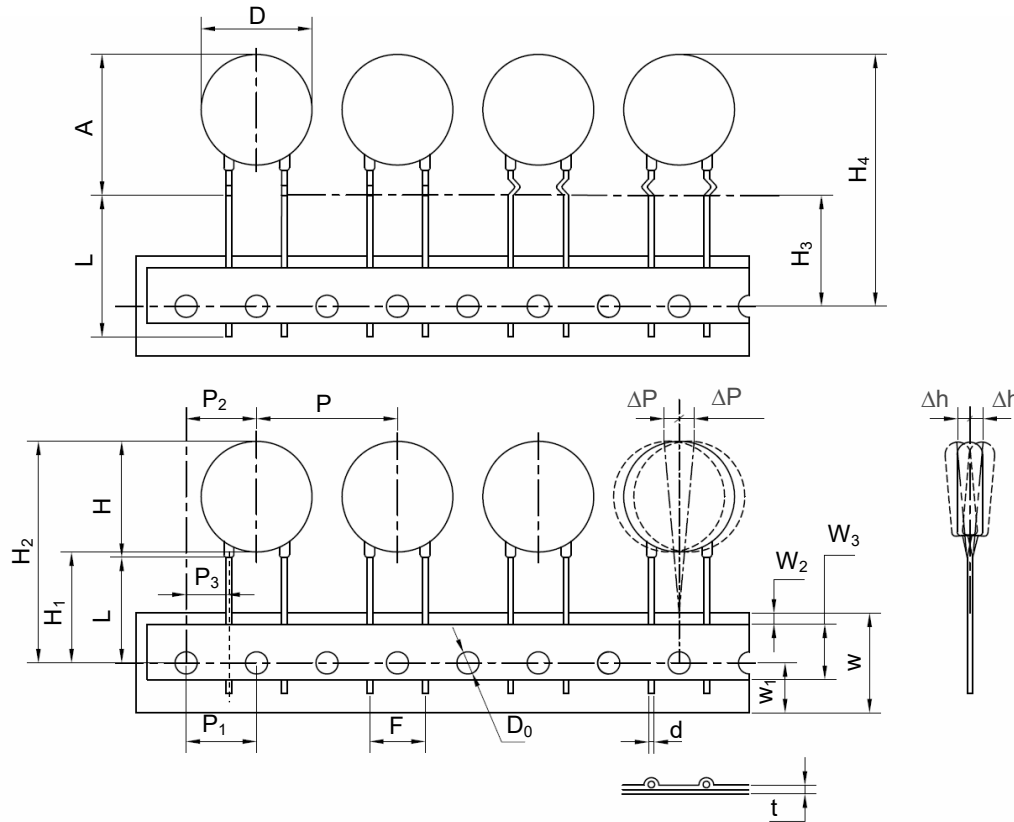

Dimensions (mm)	
P	25.4±1.0
P <sub>1</sub>	12.7±0.3
P <sub>2</sub>	12.7±1.3
P <sub>3</sub>	7.7±0.7
ΔP(max.)	1.0
W	18.0±1.0
W <sub>1</sub>	9.0±1.0
W <sub>2</sub> (max.)	3.0
W <sub>3</sub>	10.0±2.0
H(max.)	25.5
H <sub>1</sub>	18.0
H <sub>2</sub> (max.)	45.0 <sup>+2.0</sup> <sub>-0</sub>
H <sub>3</sub>	18.0
H <sub>4</sub> (max.)	48.0 <sup>+2.0</sup> <sub>-0</sub>
Δh(max.)	2.0
t (max.)	0.6
D(max.)	23.0
D <sub>0</sub>	4.0±0.2
d	1.00±0.05
A(max.)	27.5
F	10.0±1.0
L(min.)	Taping

- Tape Packaging Quantity & Weight.

Series	Nominal Varistor Voltage (V)	Box (PCS)	Carton (PCS)	G. W / Carton (365 × 265 × 415) (kg)±10%
20D	102 ~ 122	250	1500	18 ~ 22
	751 ~ 911	300	1800	17 ~ 20
	621 ~ 681	350	2100	17 ~ 18
	471 ~ 561	400	2400	16 ~ 17
	391 ~ 431	450	2700	15 ~ 16
	680			16
	301 ~ 361	500	3000	15 ~ 16
	560			15
	221 ~ 271	550	3300	13 ~ 15
	151			15
	390 ~ 470			13 ~ 15
	181 ~ 201	600	3600	13 ~ 14
	820 ~ 121			11 ~ 14
	220 ~ 330			11 ~ 14

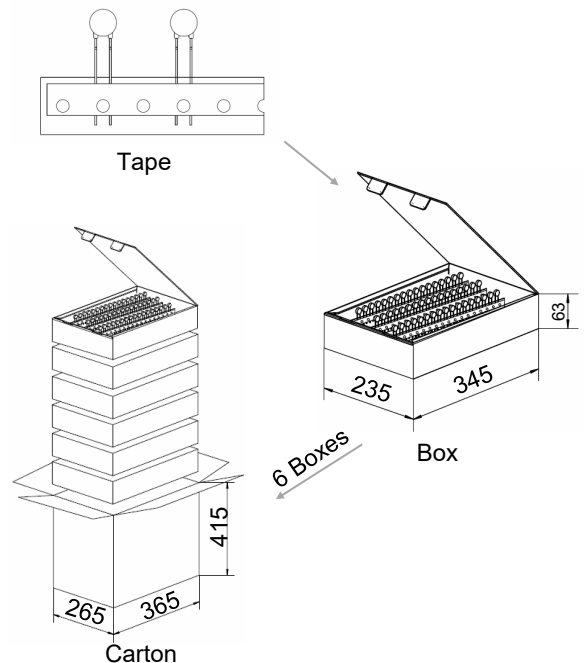

**Packaging Information**

- Tape Packaging (Code: 1EB)

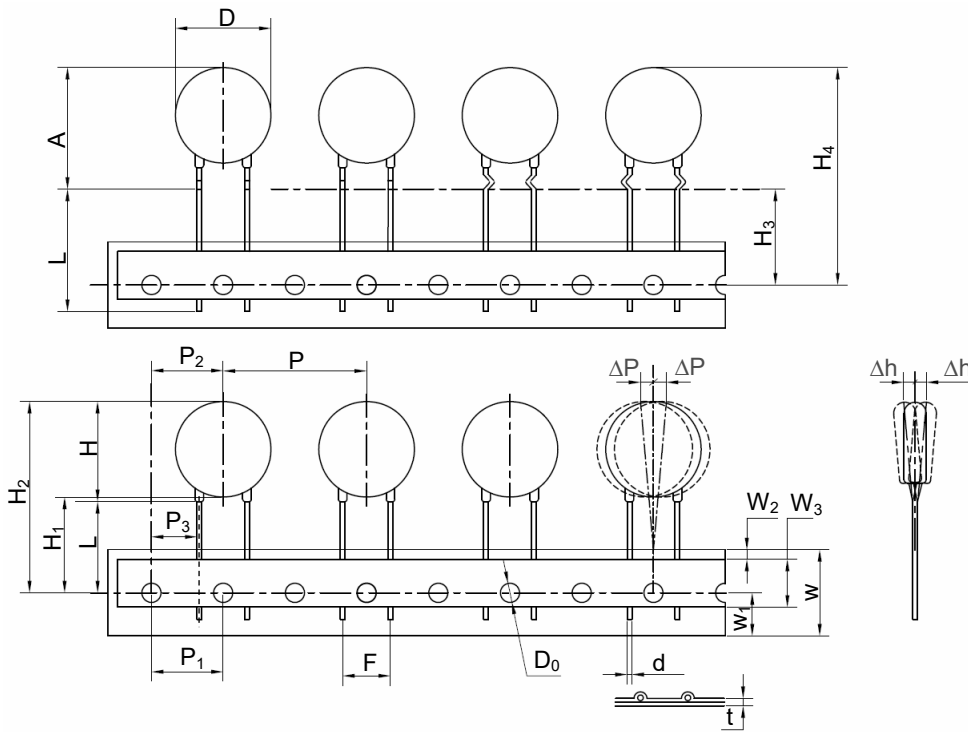

Dimensions (mm)	
P	30.0±1.0
P <sub>1</sub>	15.0±0.3
P <sub>2</sub>	15.0±1.3
P <sub>3</sub>	10.0±1.0
ΔP(max.)	1.0
W	18.0±1.0
W <sub>1</sub>	9.0±1.0
W <sub>2</sub> (max.)	3.0
W <sub>3</sub>	10.0±2.0
H(max.)	25.5
H <sub>1</sub>	18.0
H <sub>2</sub> (max.)	45.0 <sup>+2.0</sup> <sub>-0</sub>
H <sub>3</sub>	18.0
H <sub>4</sub> (max.)	48.0 <sup>+2.0</sup> <sub>-0</sub>
Δh(max.)	2.0
t(max.)	0.6
D(max.)	23.0
D <sub>0</sub>	4.0±0.2
d	1.00±0.05
A(max.)	27.5
F	10.0±0.5
L(min.)	Taping

- Tape Packaging Quantity & Weight.

Series	Nominal Varistor Voltage (V)	Box (PCS)	Carton (PCS)	G. W / Carton (365 × 265 × 415) (kg)±10%
20D	102 ~ 122	200	1200	14 ~ 16
	251 ~ 911	250	1500	14 ~ 16
	561 ~ 681	300	1800	13 ~ 15
	431 ~ 511	350	2100	13 ~ 14
	331 ~ 391	400	2400	12 ~ 14
	560 ~ 680			12 ~ 13
	241 ~ 301	450	2700	11 ~ 13
	390 ~ 470			11 ~ 12
	181 ~ 221	500	3000	10 ~ 12
	820 ~ 121			10 ~ 11
	220 ~ 330			9 ~ 11

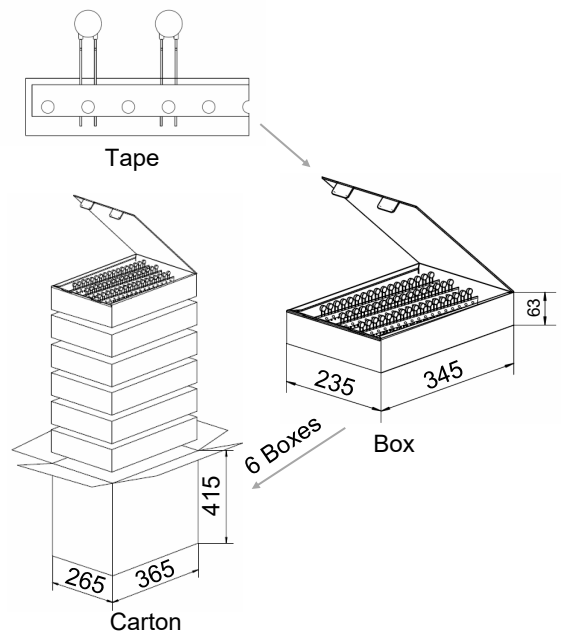



## Installation

### Mechanical Stress

Do not knock MOV when installing, to avoid mechanical damage.

## Soldering Parameters

### Wave Soldering Parameters

The wave soldering parameters are for reference only. When MOV is for practice use, some related validation is recommended.

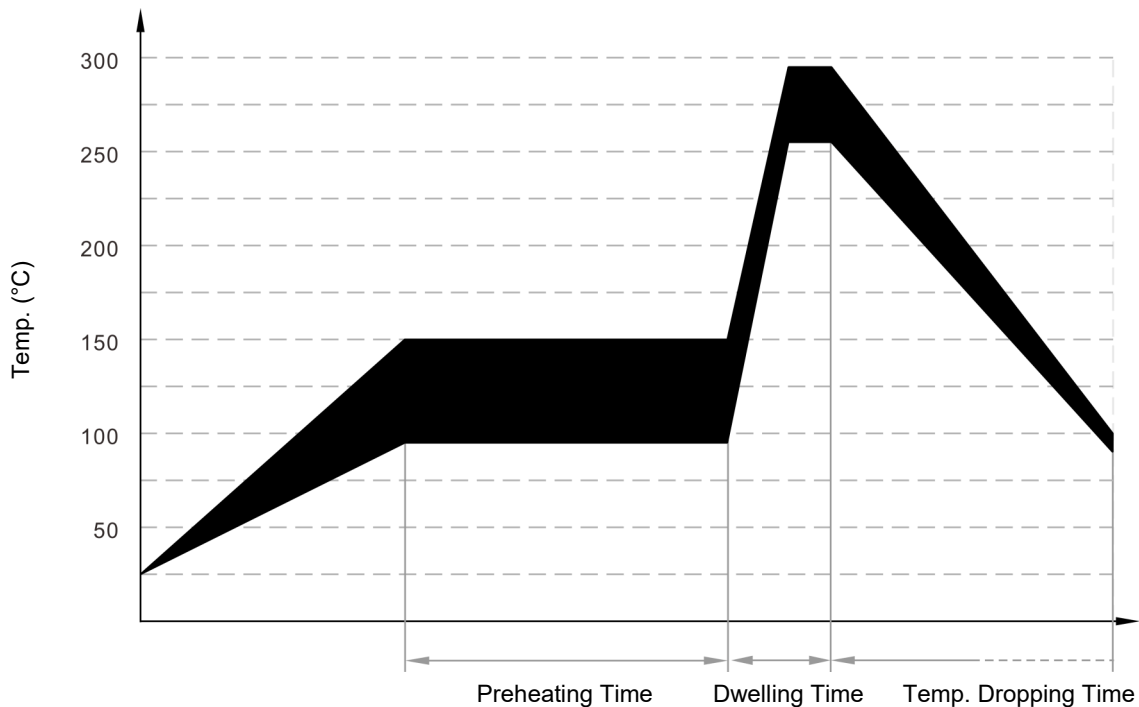

Wave Soldering Curve

Item	Temp. (°C)	Time (s)
Preheating	90 to 150	<150
Dwelling	255 to 290	3 to 10

## Recommended Hand-Soldering Parameters

Item	Condition
Temp. of Solder Head	350 °C (max.)
Soldering Time	4 seconds (max.)

## Glossary

Item	Description
$V_N$	<b>Nominal Varistor Voltage</b> Voltage, at specified D.C. current used as a reference point in the component characteristics. — (GB 18802.331) — (IEC 61051-1)
$I_L$	<b>Leakage Current</b> Measuring at 75% of varistor voltage. — (GB/T 10193) — (IEC 61051-1)
UCT	<b>Upper Category Temp.</b> Max. ambient temp. for which a varistor has been designed to operate continuously. — (GB/T 10193) — (IEC 61051-1)
LCT	<b>Lower Category Temp.</b> Minimum ambient temp. at which a varistor has been designed to operate continuously. — (GB/T 10193) — (IEC 61051-1)
Max. Peak Current	<b>Max. Peak Current</b> Max. current per pulse, which may be passed by a varistor at an ambient temp. of 25 °C, for a given number of pulses. — (GB/T 10193) — (IEC 61051-1)
$V_C$	<b>Clamping Voltage</b> Peak voltage developed across the varistor terminations under standard atmospheric conditions, when passing an 8/20 $\mu$ s class current pulse. — (GB 18802.331) — (IEC 61051-1)
Voltage Proof	<b>Voltage Proof</b> Max. peak voltage, which may be applied under continuous operating conditions between the varistor terminations and any conducting mounting surface (Applicable only to insulated varistors). — (GB/T 10193) — (IEC 61051-1)
$C_V$	<b>Capacitance</b> Capacitance across the MOV measured at a specified frequency and voltage. — (GB 18802.331) — (IEC 61051-1)
$V_{ac}$	<b>Max. Continuous a.c. Voltage</b> Max. a.c. r.m.s. voltage of a substantially sinusoidal waveform (less than 5% total harmonic distortion) which can be applied to the component under continuous operating conditions at 25 °C. — (GB/T 10193) — (IEC 61051-1)
$V_{dc}$	<b>Max. Continuous d.c. Voltage</b> Max. d.c. voltage (with less than 5% ripple) which can be applied to the component under continuous operating conditions at an ambient temp. of 25 °C. — (GB/T 10193) — (IEC 61051-1)
$I_{max}$	<b>Max. Discharge Current</b> Crest value of a current through the SPD having an 8/20 $\mu$ s waveshape and magnitude according to the manufacturers specification. $I_{max}$ is equal to or greater than $I_n$ . — (GB 18802.1) — (IEC 61643-11)



# ATTENTION

## Usage

1. Varistor must operated in the specified ambient temp.
2. Do not clean the varistor with strong polar solvent such as ketone, esters, benzene and halogenated hydrocarbon.
3. Please do not apply severe vibration, shock or pressure to MOV.
4. Please fix lead wires when bending or cutting. The distance between the bending point and the sealing of MOV shall be greater than 2 mm.

## Replacement

If varistor is visually damaged, please replace it.

## Storage

1. Storage Temp. Range: (-40 to +125) °C.
2. Relative Humidity : ≤75% RH.
3. Altitude: <2000 m.
4. Do not store the MOV at the high temp., high humidity or corrosive gas environment, to avoid influencing the solder-ability of the lead wires, the product shall be used up within 1 year after receiving the goods.

## Environmental Conditions

1. Varistor should neither be exposed to the open air, nor direct sunshine.
2. Varistor should avoid rain, water vapor or other condition of high temp. and high humidity.
3. Varistor should avoid sand dust, salt spray, or other harmful gases.

## Max. Typical Capacitance of Varistor

The typical capacitance of varistor is listed in the specifications. Designers may refer to it when designing MOV in high frequency circuit.

**Metal Oxide Varistor-High Surge Type (MOV) Feature & Model List Overview**

Nominal Operating Voltage $U_n$ (V)		Model				Maximum Continuous Operating Voltage $U_n$ (V)		Page	
		SFV14D	SFV20D	SFV25S	SFV34S	AC	DC	AC	DC
480V	500V			SFV25S122K	SFV34S122K	750	990		
				SFV25S112K	SFV34S112K	680	895		
				SFV25S102K	SFV34S102K	625	825		
				SFV25S911K	SFV34S911K	550	745		
				SFV25S821K	SFV34S821K	510	670		
415V	500V			SFV25S751K	SFV34S751K	460	615		
		SFV14D681K	SFV20D681K	SFV25S681K	SFV34S681K	420	560		
380V	500V	SFV14D621K	SFV20D621K	SFV25S621K	SFV34S621K	385	505		
		SFV14D561K	SFV20D561K	SFV25S561K	SFV34S561K	350	460		
100V	240V	SFV14D511K	SFV20D511K	SFV25S511K	SFV34S511K	320	415		
		SFV14D471K	SFV20D471K	SFV25S471K	SFV34S471K	300	385		
240V	250V	SFV14D431K	SFV20D431K	SFV25S431K	SFV34S431K	275	350		
		SFV14D391K	SFV20D391K	SFV25S391K	SFV34S391K	250	320		
100V	250V	SFV14D361K	SFV20D361K	SFV25S361K	SFV34S361K	230	300		
		SFV14D331K	SFV20D331K	SFV25S331K	SFV34S331K	210	275		
120V	250V	SFV14D301K	SFV20D301K	SFV25S301K	SFV34S301K	190	250		
		SFV14D271K	SFV20D271K	SFV25S271K	SFV34S271K	175	225		
100V	125V	SFV14D241K	SFV20D241K	SFV25S241K	SFV34S241K	150	200		
		SFV14D221K	SFV20D221K			140	180		
	125V	SFV14D201K	SFV20D201K			130	170		
						115	150		
48V	125V					95	125		
						75	100		
24V	125V					60	85		
						50	65		
12V	125V					40	56		
						35	45		
12V	125V					30	38		
						25	31		
12V	125V					20	26		
						17	22		
12V	125V					14	18		
AC	DC	8	13	27.5	50	AC	DC		